



	Page
<b>- SPECIFICATIONS</b>	<b>200</b>
PERFORMANCE RANGE and SELECTION CHART	201
TYPE KEY and CURVE SPECIFICATIONS	202
PERFORMANCE CURVE PRA 0.50	203
PERFORMANCE CURVE PRA 0.80	204
PERFORMANCE CURVE PRA 1.00	205
PERFORMANCE CURVE PRA 1.50	206
PERFORMANCE CURVE PRA 2.00	207
<b>- CONSTRUCTIONS</b>	<b>300</b>
SECTIONAL VIEW DRAWING	300
SECTIONAL VIEW TABLE	301
MECHANICAL SEAL	302
BEARINGS	303
<b>- DIMENSIONS AND WEIGHT</b>	<b>400</b>
PUMP	400
PACKING	401
<b>- TECHNICAL DATA</b>	<b>500</b>
MOTOR DATA	500
NOISE DATA	500

## SPECIFICATION

50Hz

Rev. K

PUMP		
Liquid	Type of liquid	Clean water
Handled	Temperature [°C]	min. +5 max. +80
Maximum working pressure	[MPa]	0.6 (PRA 0.50) 0.75 (PRA 0.80) 1.2 (PRA 1.00-1.50-2.00)
Construction	Impeller	Peripheral turbine type
	Shaft seal type	Mechanical seal
	Bearing	Sealed ball bearing
Pipe Connection	Suction [inch]	G 1 UNI ISO 228
	Discharge [inch]	G 1 UNI ISO 228
Material	Casing	Cast iron
	Impeller	Brass
	Shaft seal	Ceramic/Carbon/NBR
	Shaft	Carbon steel - AISI 303 (wet extension)
	Bracket	Cast iron
Applicable standard of test		ISO 9906:2012 – Grade 3B

MOTOR		
Type	Electric - TEFC	
Efficiency level (Reg. 640/2009)	-	- from 0.37 kW up to 0.6 kW IE2 from 0.75 kW up to 1.5 kW IE3 from 0.75 kW up to 1.5 kW
No. of Poles	2	
Rotation speed [min <sup>-1</sup> ]	≈ 2850	
Insulation Class	Class F	
Protection degree (CEI EN 60034-5)	IP 44	
Power rating [kW]	0.37 ÷ 1.5	
[HP]	0.5 ÷ 2	
Frequency [Hz]	50	
Voltage [V]	230 ±10%	230/400 ±10%
Capacitor	Built in	-
Over load protection	Built in	Provided by the user
Casing material	Aluminium	
Base material	Aluminium	
Dimensions of cable entry	PG 11 - PG 13.5 - M16x1.5 - M20x1.5 (see dimensions page 400)	

**SELECTION CHART**

**50Hz**

Rev. K

**PERFORMANCE RANGE**

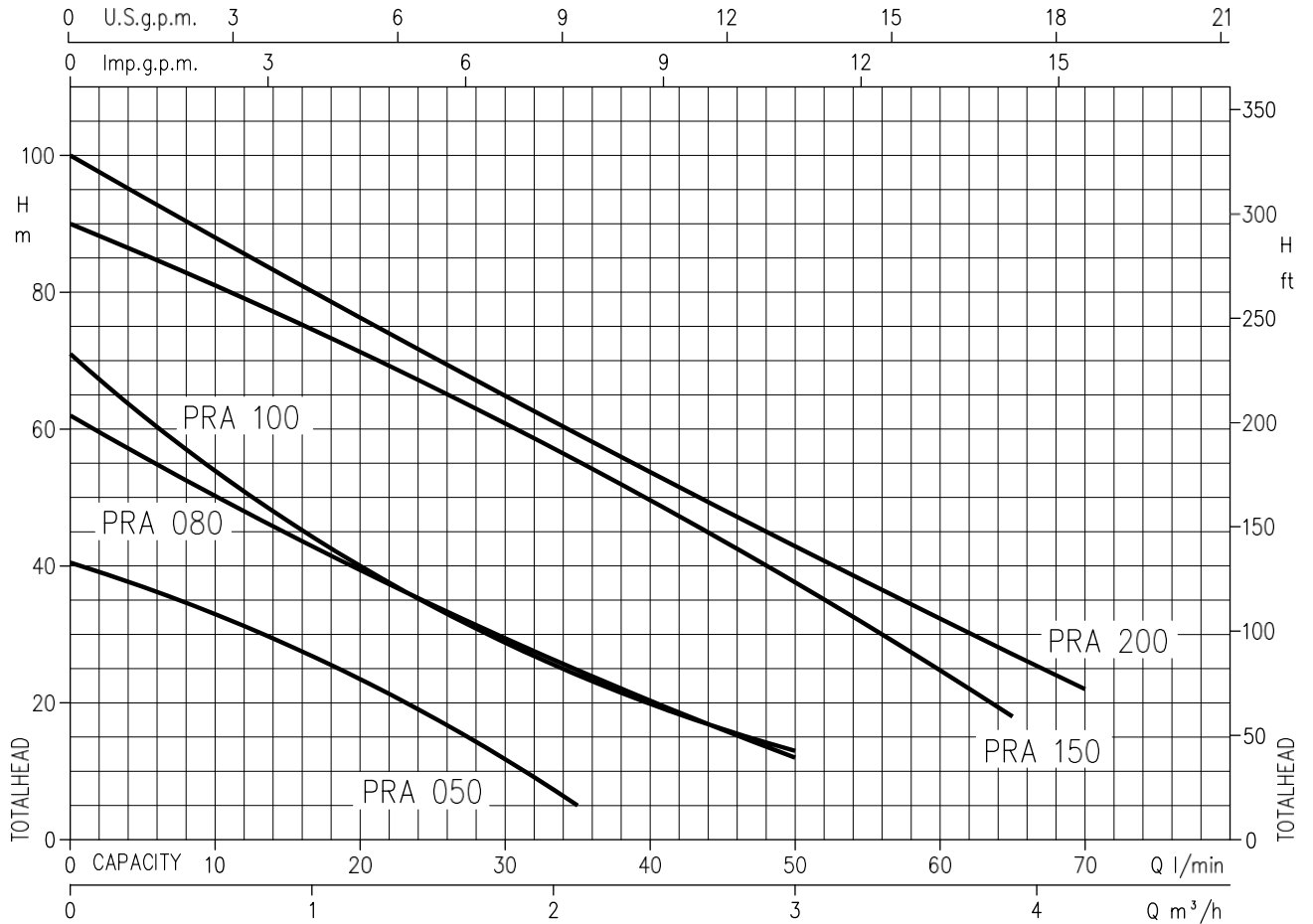

**SELECTION CHART**

Pump Type		Power		Q=Capacity									
Single phase	Three phase	[kW]	[HP]	l/min	5	10	15	20	35	50	65	70	
				m³/h	0.3	0.6	0.9	1.2	2.1	3	3.9	4.2	
				H=Total manometric head in meters									
PRA 0.50 M	PRA 0.50 T	0.37	0.5	40.5	37	33.3	28.7	23.7	5	-	-	-	
PRA 0.80 M	PRA 0.80 T	0.6	0.8	62	56	50.7	45.1	39.8	25	12	-	-	
PRA 1.00 M	PRA 1.00 T	0.75	1	71	62	54.4	47	40.4	24.3	13	-	-	
PRA 1.50 M	PRA 1.50 T	1.1	1.5	90	-	81	76.9	71.9	55.8	37.9	18	-	
PRA 2.00 M	PRA 2.00 T	1.5	2	100	-	88	82.9	77	59.8	43.3	27.4	22	

**TYPE KEY**

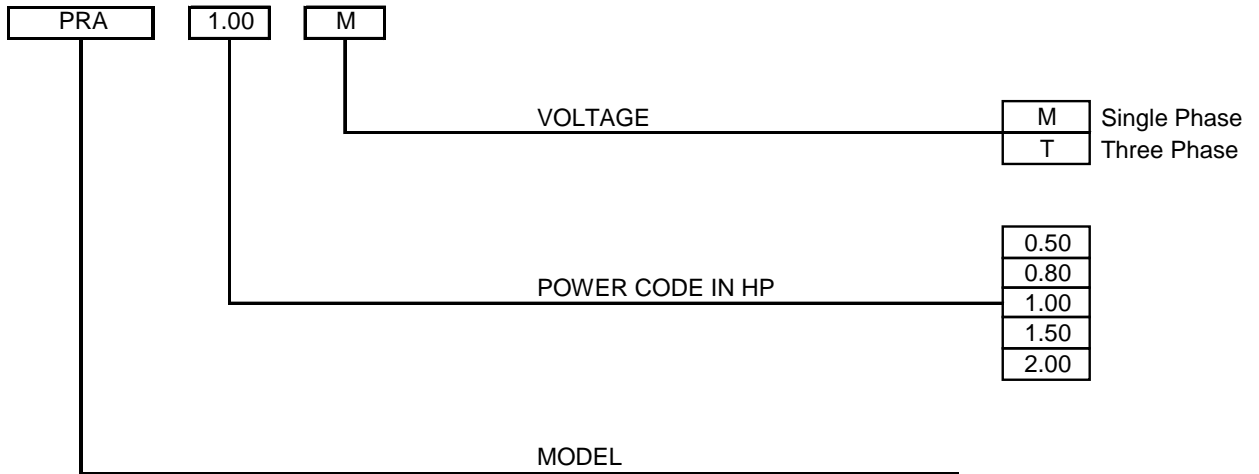

**PERFORMANCE CURVE SPECIFICATIONS**

The specifications below qualify the curves shown on the following pages.

Tolerances according to ISO 9906:2012 – Grade 3B

The curves refer to effective speed of asynchronous motors at 50 Hz, 2 poles.

Measurements were carried out with clean water at 20°C of temperature and with a kinematic viscosity of  $\nu = 1 \text{ mm}^2/\text{s}$  (1 cSt)

In order to avoid the risk of over-heating, the pumps should not be used at a flow rate below 10% of best efficiency point.

Symbols explanation:

Q = volume flow rate

H = total head

PRA 0.50 (0.37 kW) - Impeller diameter = 60 mm

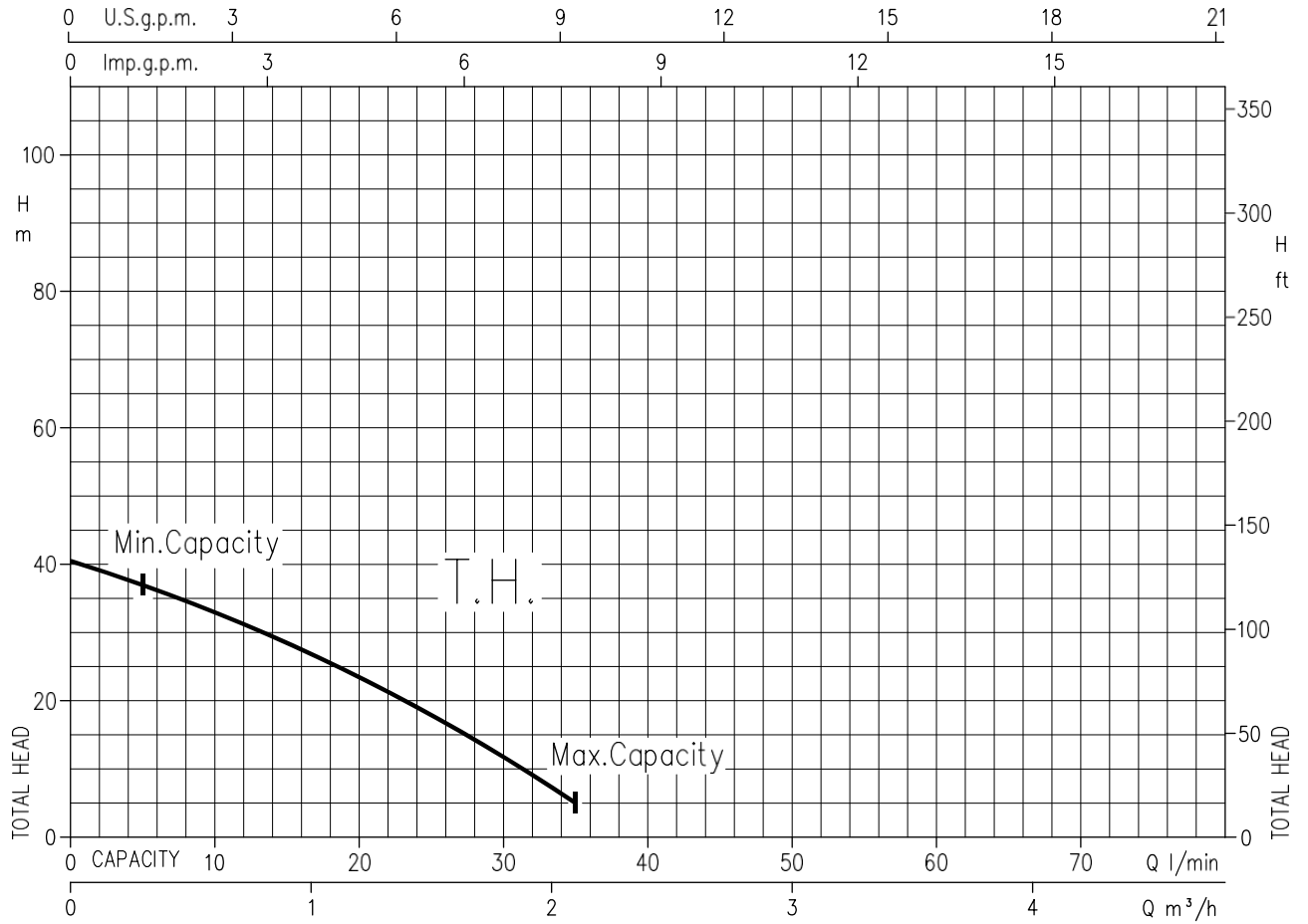

Rotation speed  $\approx 2850 \text{ min}^{-1}$   
Test standard: ISO 9906:2012 – Grade 3B

PRA 0.80 (0.6 kW)- Impeller diameter = 70 mm

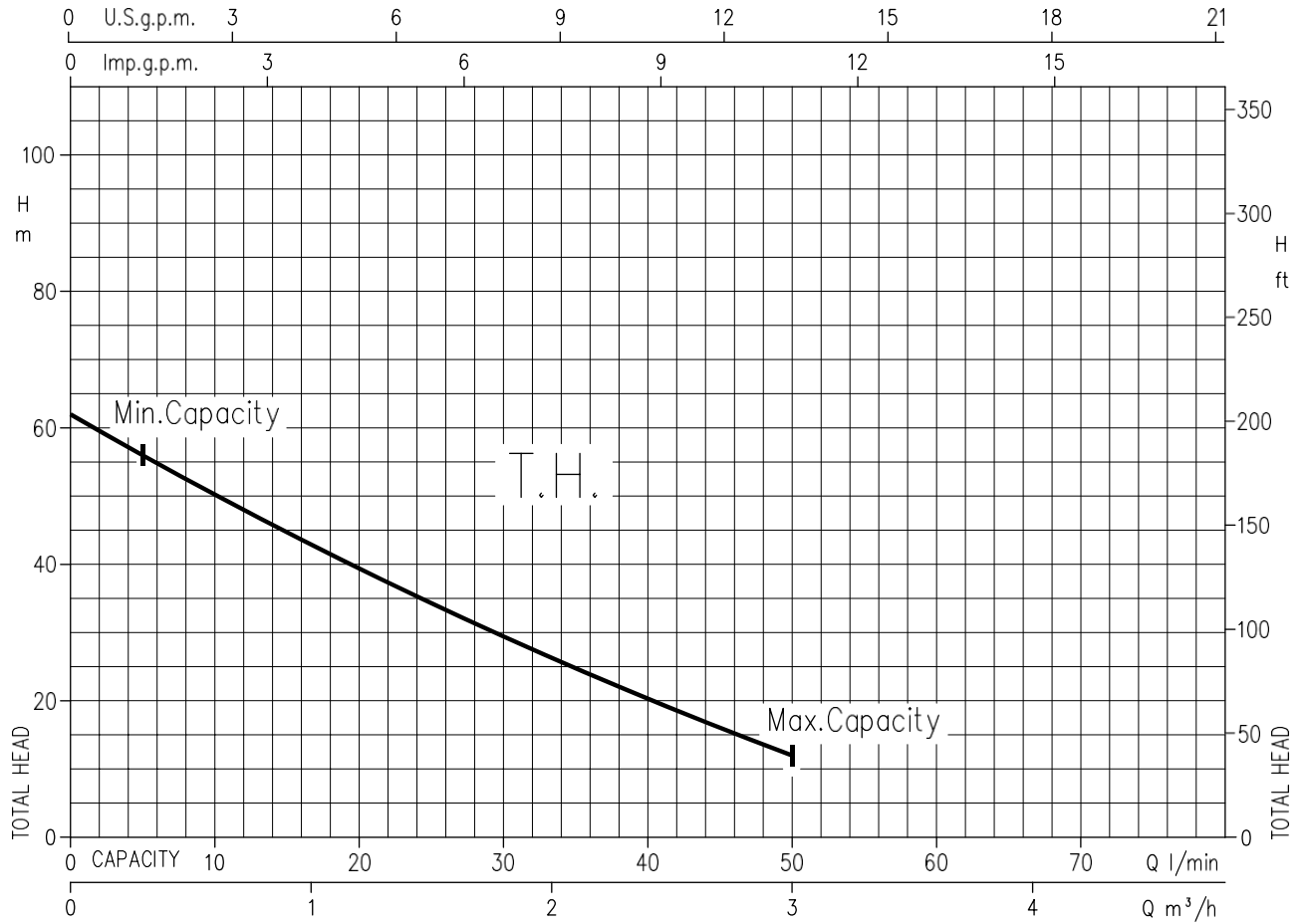

Rotation speed  $\approx 2850 \text{ min}^{-1}$   
Test standard: ISO 9906:2012 – Grade 3B

PRA 1.00 (0.75 kW)- Impeller diameter = 70.8 mm

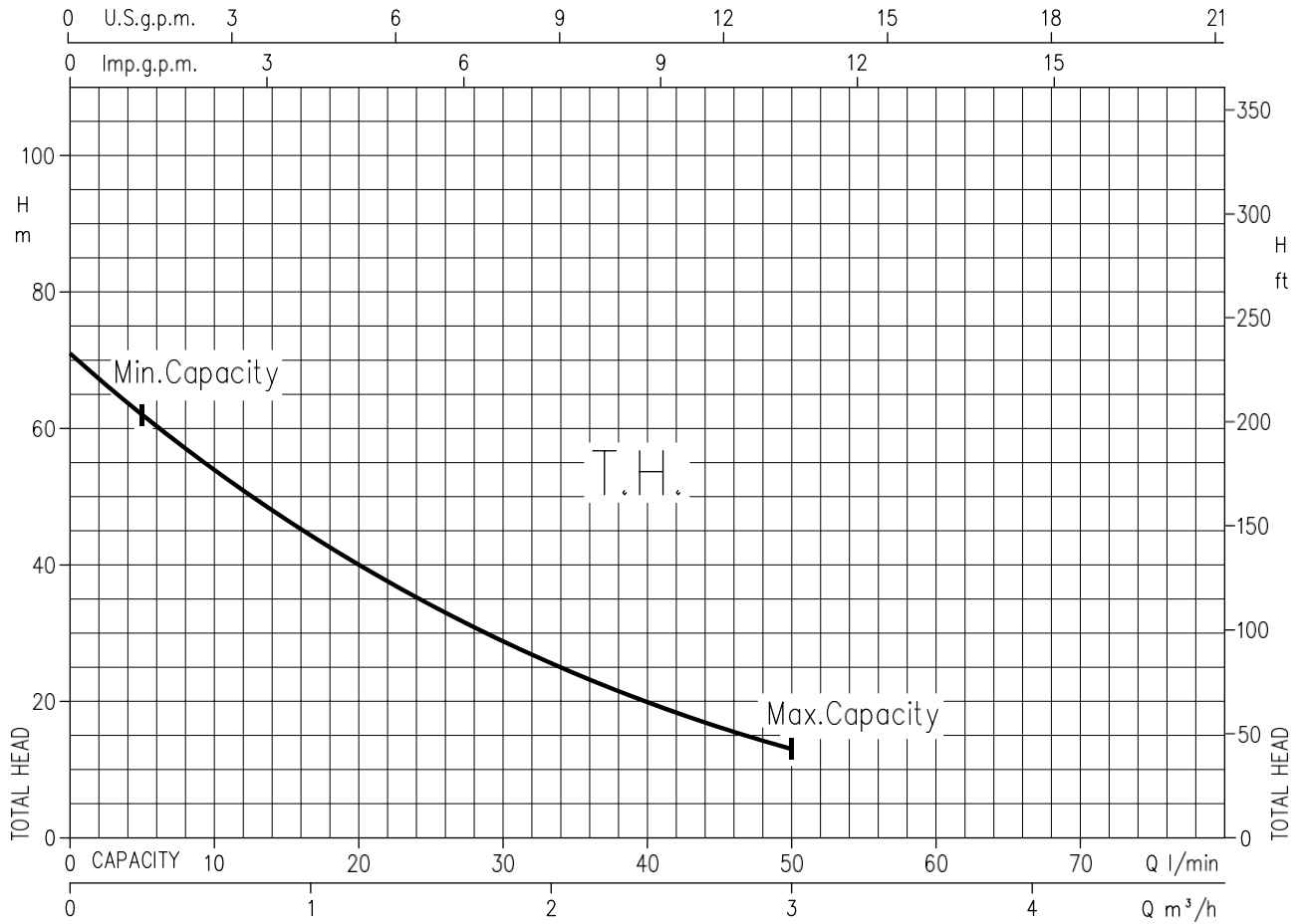

Rotation speed  $\approx 2850 \text{ min}^{-1}$   
Test standard: ISO 9906:2012 – Grade 3B



PRA 1.50 (1.1 kW)- Impeller diameter = 77 mm

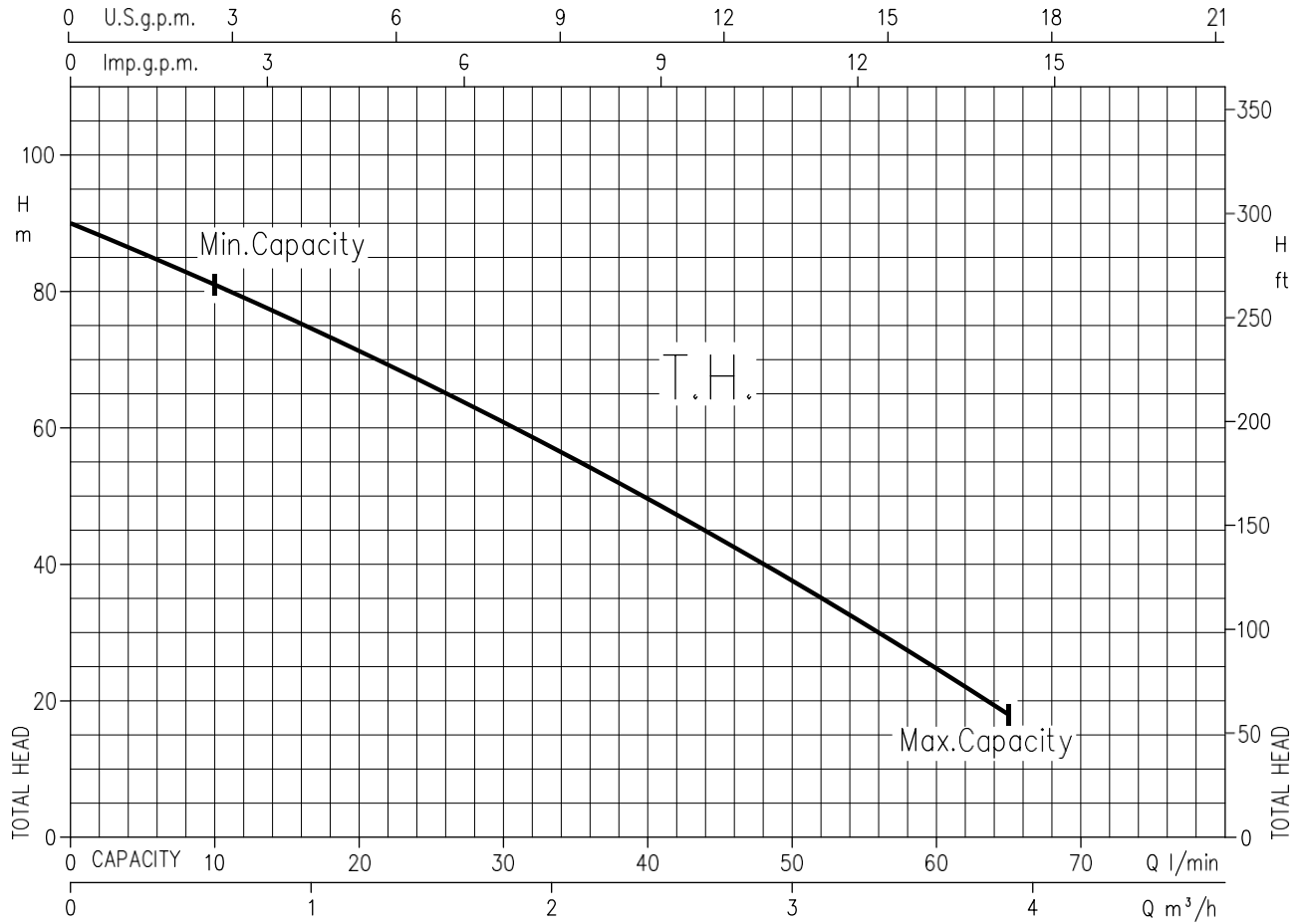

Rotation speed  $\approx 2850 \text{ min}^{-1}$   
Test standard: ISO 9906:2012 – Grade 3B

PRA 2.00 (1.5 kW)- Impeller diameter = 78.2 mm

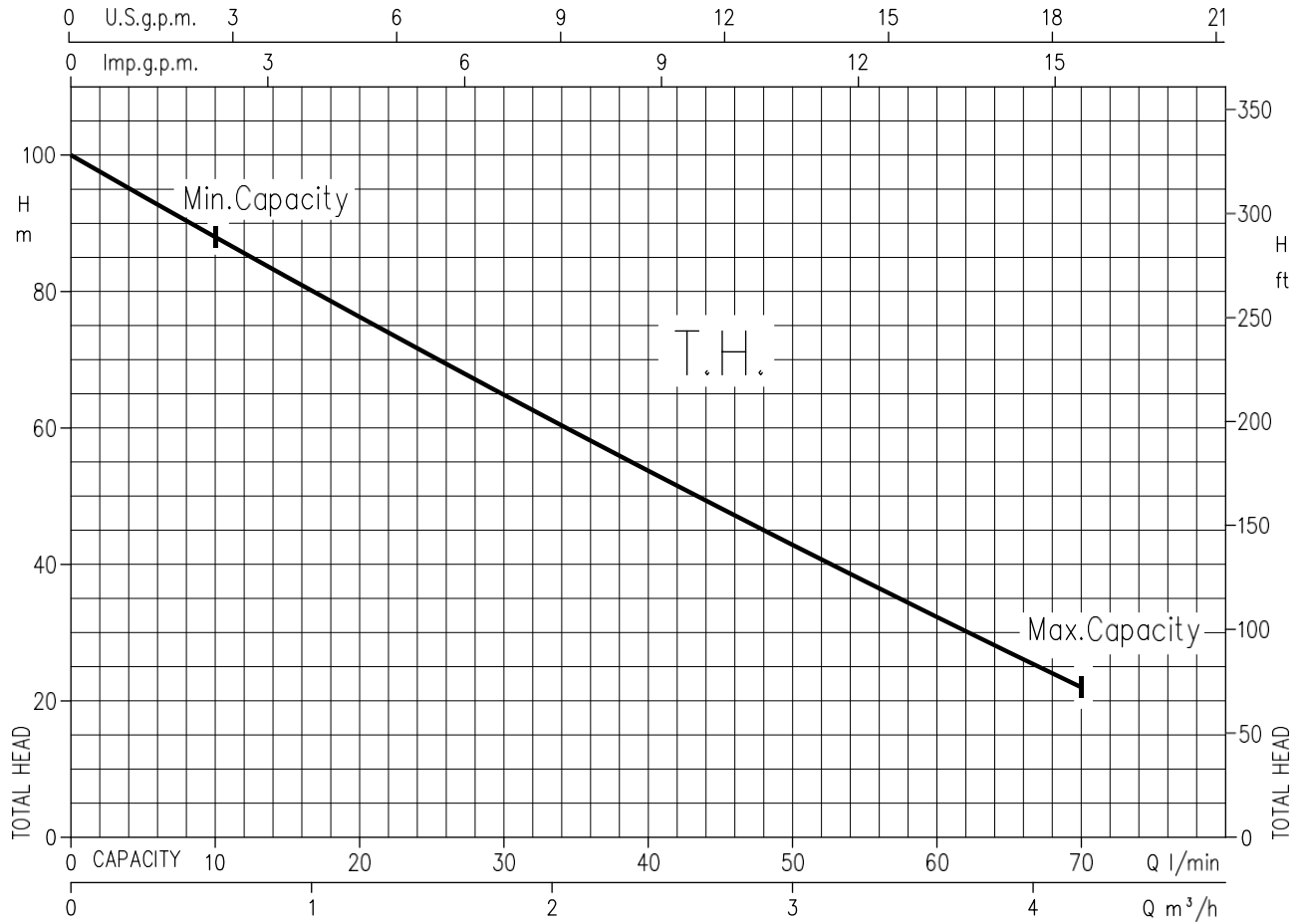

Rotation speed  $\approx 2850 \text{ min}^{-1}$   
Test standard: ISO 9906:2012 – Grade 3B

SECTIONAL VIEW DRAWING

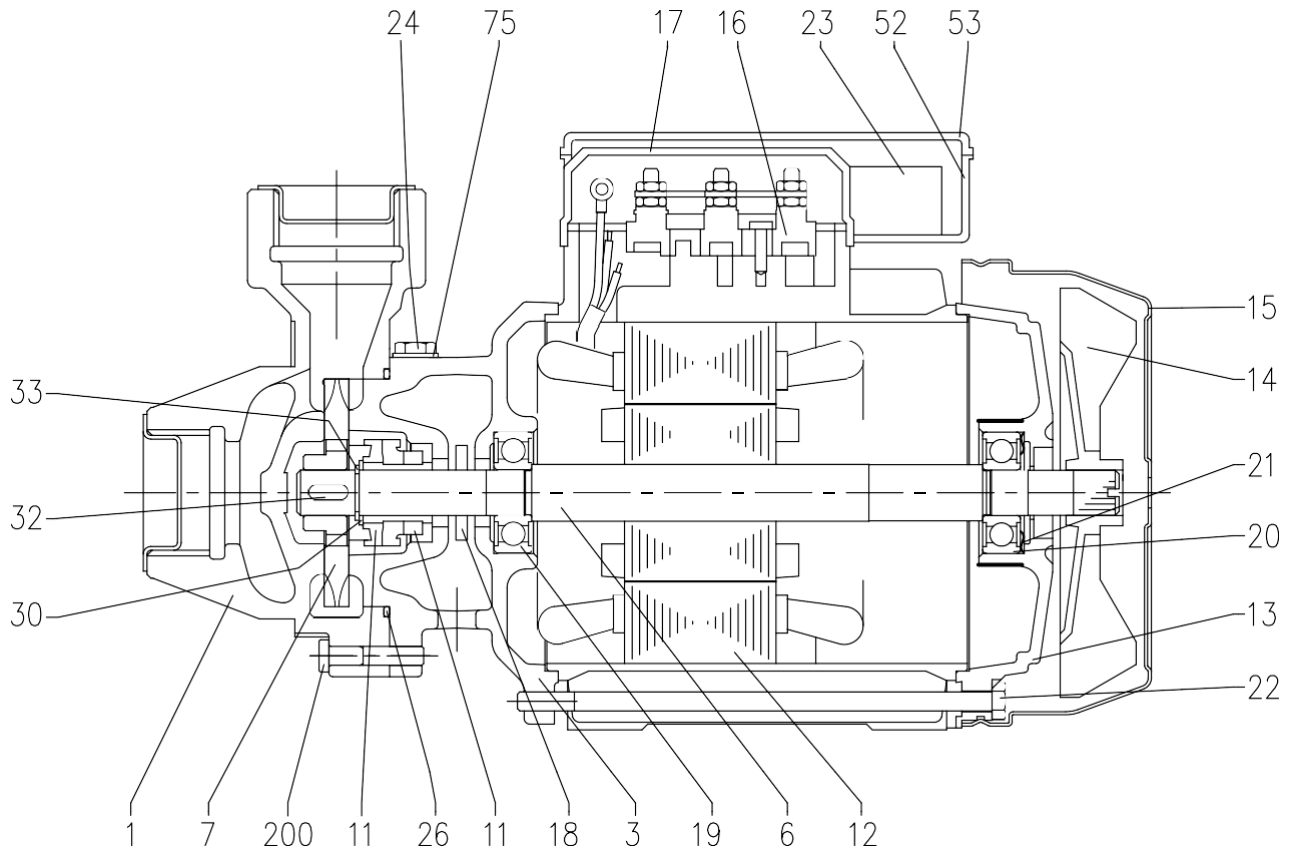

## SECTIONAL VIEW TABLE

N°	PART NAME	MATERIAL	DIMENSIONS	STANDARD	Q.TY
1	Casing	Cast iron			1
3	Motor bracket	Cast iron			1
6	Shaft with rotor	[1]		UNI 7846	1
7	Impeller	Brass			1
11	Mechanical seal [2]	Carbon/Ceramic/NBR	See pag.302-303		1
12	Motor frame with stator	-			1
13	Motor cover	Aluminium			1
14	Fan	PP			1
15	Fan cover	Fe P04 Galvanized			1
16	Terminal box	-			1
17	Terminal box cover [3]	Aluminium			1
18	Splash ring	NBR			1
19	Pump side ball bearing	-			1
20	Fan side ball bearing	-			1
21	Adjusting ring	Steel C70			1
22	Tie rod	Fe 42 Galvanized			4
23	Capacitor [4]	-			1
24	Priming plug	Brass	G 1/8"	UNI 338	1
26	O-Ring	NBR			1
30	Washer	AISI 304			1
32	Key	AISI 316			1
33	Seeger ring	AISI 304		UNI 7435	1
52	Capacitor box [4]	ABS class V-0			1
53	Capacitor box cover [4]	ABS class V-0			1
75	Washer	Aluminium			1
200	Screw	Zn Steel Cl. 8.8	0.37 kW	UNI 5938	3
			0.6-0.75 kW	ISO 898-1	
			1.1-1.5 kW		

- [1] Material: AVZ for version PRA 0.50  
AISI 303 (wet extension) for the other version
- [2] See constructions mechanical seal page 301-302
- [3] Only for three phase
- [4] Only for single phase

**MECHANICAL SEAL  
(UP TO 0.75 kW)**

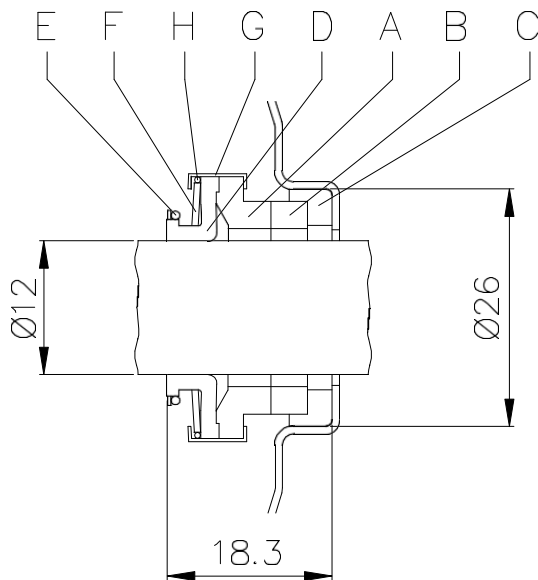

REF	PART NAME	MATERIAL
A	Rotary seal ring	Carbon graphite
B	Stationary seal ring	Ceramic
C	Gasket	NBR
D	Bellows	NBR
E	Ring	AISI 304
F	Self driving spring	AISI 304
G	Frame	AISI 304
H	Retainer ring	AISI 304

**MECHANICAL SEAL  
(1.1 kW AND ABOVE)**

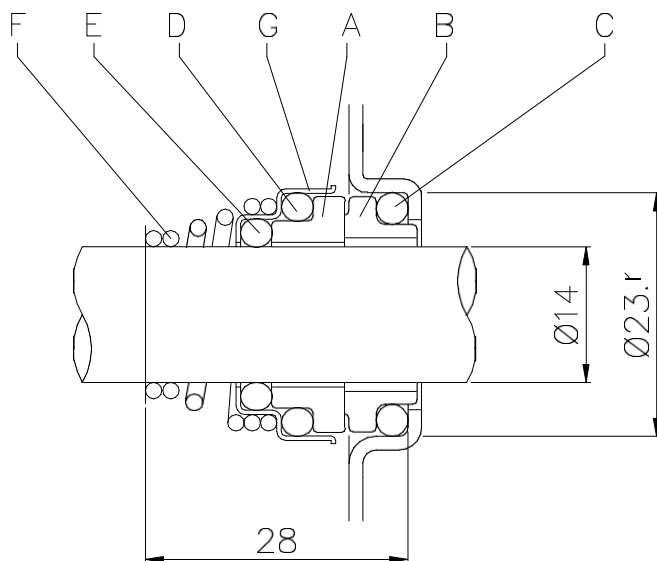

REF	PART NAME	MATERIAL
A	Rotary seal ring	Ceramic
B	Stationary seal ring	Carbon graphite
C	O Ring	NBR
D	O Ring	NBR
E	O Ring	NBR
F	Self driving spring	AISI 316
G	Frame	AISI 304

## BEARINGS

Pump Type		Ball bearing			
Single phase	Three phase	Pump side	(*) Pump side	Fan side	(*) Fan side
PRA 0.50 M	PRA 0.50	6201 2RSH	-	6201 2RSH	-
PRA 0.80 M	PRA 0.80	6202 2RSH	-	6202 2RSH	-
PRA 1.00 M	PRA 1.00	6202 2RSH	6202-ZZ C3	6202 2RSH	6202-ZZ C3
PRA 1.50 M	PRA 1.50	6204 2RSH	6204-ZZ C3	6203 2RSH	6203-ZZ C3
PRA 2.00 M	PRA 2.00	6204 2RSH	6204-ZZ C3	6203 2RSH	6203-ZZ C3

(\*) Only for IE3 Motors

### PUMP

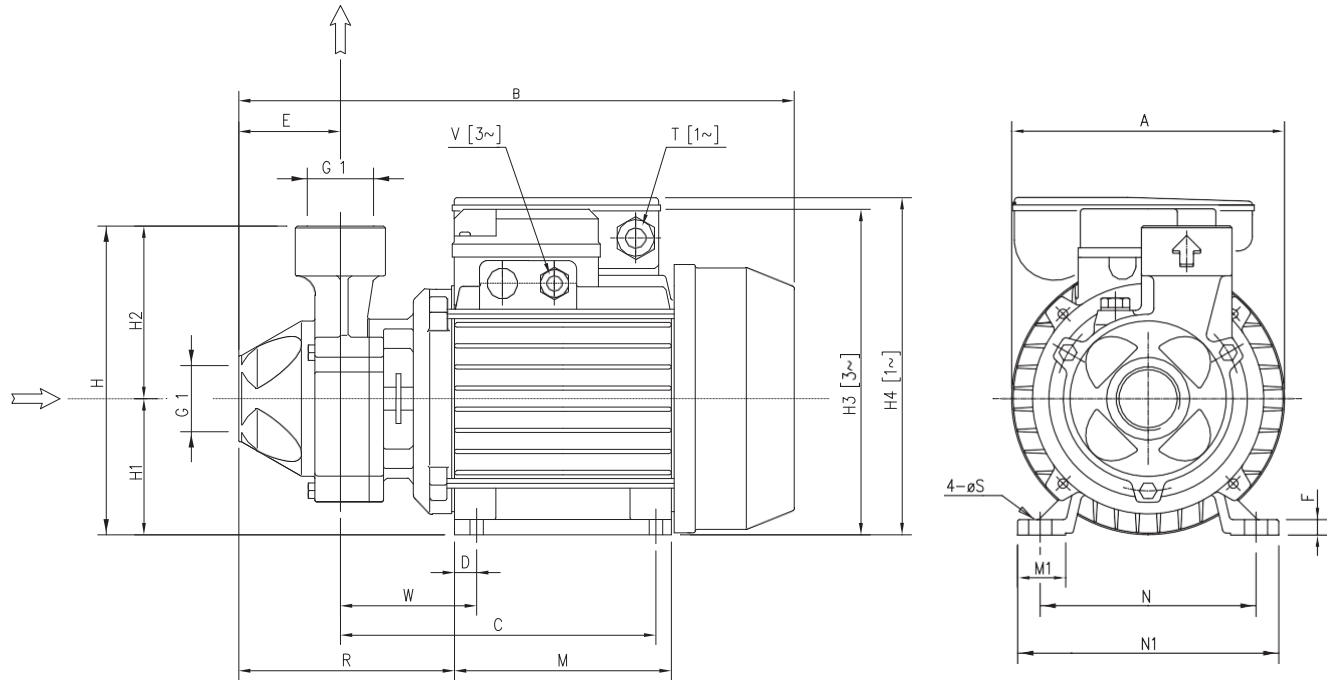

Pump Type	Dimensions [mm]																				Weight [kgf]			
	A	B	(*)	C	D	E	F	H	H1	H2	H3	H4	M	M1	N	N1	R	[1~] T	[3~] (*) V	[3~] V	W	S	(*)	
PRA 0.50M	130	264	-	149	10	50	7	143	63	80	-	160	100	23	100	120	119	PG11	-	-	69	7	5.6	-
PRA 0.50T	130	264	-	149	10	50	7	143	63	80	150	-	100	23	100	120	119	-	-	PG11	69	7	5.6	-
PRA 0.80M	130	291	-	159	11	54	9	161	71	90	-	178	112	25	112	135	122	PG11	-	-	69	7	9.2	-
PRA 0.80T	150	291	-	159	11	54	9	161	71	90	168	-	112	25	112	135	122	-	-	PG11	69	7	9.2	-
PRA 1.00M	150	291	-	159	11	54	9	161	71	90	-	178	112	25	112	135	122	PG11	-	-	69	7	9.7	-
PRA 1.00T	150	291	291	159	11	54	9	161	71	90	168	-	112	25	112	135	122	-	M16x1.5	PG11	69	7	10.5	10.5
PRA 1.50M	162	331	-	188	12	57	12	175	80	95	-	212	124	28	125	152	144	PG13.5	-	-	88	9	14.5	-
PRA 1.50T	162	331	356	188	12	57	12	175	80	95	187	-	124	28	125	152	144	-	M20x1.5	PG11	88	9	15.5	16.4
PRA 2.00M	162	331	-	188	12	57	12	175	80	95	-	212	124	28	125	152	144	PG13.5	-	-	88	9	15.8	-
PRA 2.00T	162	344	357	188	12	57	12	175	80	95	187	-	124	28	125	152	144	-	M20x1.5	PG11	88	9	16.4	17.3

[1~] Single Phase

[3~] Three Phase

(\*) Only for IE3 Motors

PACKING

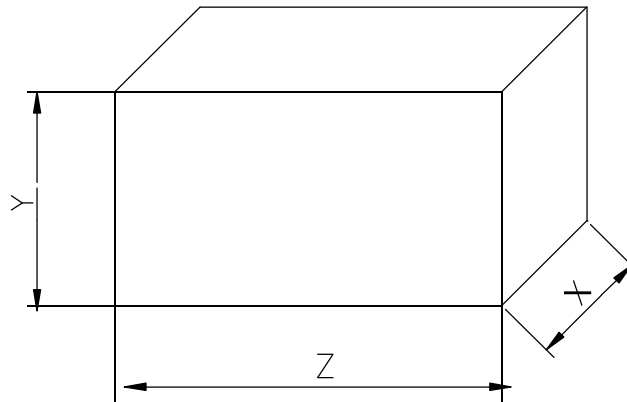

Pump Type		Packing [mm]						Weight [kgf]		
Single Phase	Three Phase	X		Y		Z		[1~]	[3~]	(*) [3~]
		[1~]	[3~]	[1~]	[3~]	[1~]	[3~]			
PRA 0.50 M	PRA 0.50	155	155	195	195	285	285	6.1	6.1	-
PRA 0.80 M	PRA 0.80	180	180	200	200	305	305	9.4	9.4	-
PRA 1.00 M	PRA 1.00	180	180	200	200	305	305	10.5	9.9	9.9
PRA 1.50 M	PRA 1.50	195	160	230	205	372	355	15.4	13.7	14.6
PRA 2.00 M	PRA 2.00	195	160	230	205	372	355	16.5	17	17.9

[1~] Single Phase

[3~] Three Phase

(\*) Only for IE3 Motors



### MOTOR DATA

Pump type		Power		Efficiency		Capacitor		Efficiency (% load)			Input		Full load current			Locked rotor current		
Single Phase	Three Phase	[kW]	[HP]	Single Phase	Three Phase	Single Phase	Three Phase	Three phase			Single Phase	Three Phase	[A]			[A]		
				Phase	Phase	[μF]	[V]	50%	75%	100%	Phase	Phase	230 V	230 V	400 V	230 V	230 V	400 V
PRA 0.50 M	PRA 0.50	0.37	0.5	-	-	10	450	-	-	-	0.57	0.55	2.6	1.7	1.0	6.9	7.0	3.8
PRA 0.80 M	PRA 0.80	0.6	0.8	-	-	16	450	-	-	-	1.10	1.10	4.9	3.6	2.1	16.5	17.0	10
PRA 1.00 M	PRA 1.00	0.75	1	-	IE2	20	450	77.2	80.9	81.3	1.25	0.92	5.6	3.0	1.7	19.0	22.0	12.9
-	PRA 1.00	0.75	1	-	IE3	-	-	80.9	82.3	82.1	-	0.91	-	3.0	1.7	-	19.7	11.4
PRA 1.50 M	PRA 1.50	1.1	1.5	-	IE2	40	450	79.7	82.5	83.0	2.27	1.80	10.0	5.6	3.2	43.0	45.0	25.7
-	PRA 1.50	1.1	1.5	-	IE3	-	-	83.5	84.3	84.6	-	1.77	-	5.8	3.3	-	47.4	27.4
PRA 2.00 M	PRA 2.00	1.5	2	-	IE2	40	450	78.6	83.0	84.2	2.45	2.25	10.9	7.4	4.3	43.0	34.3	20.0
-	PRA 2.00	1.5	2	-	IE3	-	450	82.7	86.1	87.0	-	1.72	-	6.6	3.8	-	66.6	38.4

### NOISE DATA

Pump type		Power		L <sub>pA</sub> - dB(A) *
Single Phase	Three Phase	[kW]	[HP]	
PRA 0.50 M	PRA 0.50	0,37	0,5	<70
PRA 0.80 M	PRA 0.80	0,6	0,8	
PRA 1.00 M	PRA 1.00	0,75	1	
PRA 1.50 M	PRA 1.50	1,1	1,5	73
PRA 2.00 M	PRA 2.00	1,5	2	

\* Mean value of several measures at 1m distance around the pump.  
Tolerance ± 2.5 dB.